

Operator's Instruction Manual

MODELS TMC-7, EDG-7, TG-7



EDGER GRINDER Gasoline/Electric Powered

READ AND UNDERSTAND THE OPERATORS INSTRUCTION MANUAL *THOROUGHLY* BEFORE ATTEMPTING TO OPERATE THIS EQUIPMENT.



Death or serious injury could occur if this machine is used improperly.



SAFETY MESSAGES

- Safety Instructions are preceded by a graphic alert symbol of DANGER, WARNING, or CAUTION.



Indicates an imminent hazard which, if not avoided, will result in death or serious injury.



Indicates an imminent hazard which, if not avoided, can result in death or serious injury.



Indicates hazards which, if not avoided, could result in serious injury and or damage to the equipment.

GASOLINE/PROPANE POWERED EQUIPMENT



- Engine exhaust from this product contains chemicals known to the State of California to cause cancer, birth defects or other reproductive harm.



- Gasoline is extremely flammable and poisonous. It should only be dispensed in well ventilated areas, and with a cool engine.

- Small gasoline engines produce high concentrations of carbon monoxide (CO) example: a 5 HP 4

cycle engine operation in an enclosed 100,000 cu. ft. area with only one change of air per hour is capable of providing deadly concentrations of CO in less than fifteen minutes. Five changes of air in the same area will produce noxious fumes in less than 30 minutes. Gasoline or propane powered equipment should not be used in enclosed or partially enclosed areas. Symptoms of CO poisoning include, headache, nausea, weakness, dizziness, visual problems and loss of consciousness. If symptoms occur get into fresh air and seek medical attention immediately.

ELECTRICAL POWERED EQUIPMENT



Extreme care must be taken when operating electric models with water present: Ensure power cord is properly grounded, is attached to a Ground-Fault-Interrupter (GFI) outlet, and is undamaged.

- Check all electrical cables - be sure connections are tight and cable is continuous and in good condition. Be sure cable is correctly rated for both the operating current and voltage of this equipment.
- Improper connection of the equipment-grounding conductor can result in a risk of electric shock. Check with qualified electrician or service person if there is any doubt as to whether the outlet is properly grounded. Adhere to **all** local codes and ordinances.
- **NOTE:** In the event of a malfunction or breakdown, grounding provides a path of least resistance for the electric current to dissipate. The motor is equipped with a grounded plug and must be connected to an outlet that is properly installed and properly grounded. DO NOT modify the plug provided on the motor. If the plug does not fit the outlet have a qualified electrician install the proper receptacle.
- Switch motor OFF **before** disconnecting power.

- Do not disconnect power by pulling cord. To disconnect, grasp the plug, not the cord.
- Unplug power cord at the machine when not in use and before servicing.

GENERAL INSTRUCTIONS

- Equipment should only be operated by trained personnel in good physical condition and mental health (not fatigued). The operator and maintenance personnel must be physically able to handle the bulk weight and power of this equipment.
- This is a one person tool. Maintain a safe operating distance to other personnel. It is the **operators' responsibility** to keep other people (workers, pedestrians, bystanders, etc.) away during operation. Block off the work area in all directions with roping, safety netting, etc. for a safe distance. Failure to do so may result in others being injured by flying debris or exposing them to harmful dust and noise.
- This equipment is intended for commercial use only.
- For the operator's safety and the safety of others, always keep all guards in place during operation.
- Never let equipment run unattended.



- Personal Protection Equipment and proper safety attire must be worn when operating this machinery. The operator must wear approved safety equipment appropriate for the job such as hard hat and safety shoes when conditions require. Hearing protection **MUST** be used (operational noise levels of this equipment may exceed 90db). Eye protection **MUST** be worn at all times.



Keep body parts and loose clothing away from moving parts. Failure to do so could result in dismemberment or death.

- Do not modify the machine.

- Stop motor/engine when adjusting or servicing this equipment.



Maintain a safe operating distance from flammable materials. Sparks from the cutting-action of this machine can ignite flammable materials or vapors.

DUST WARNING



Some dust created by power sanding, sawing, grinding, drilling and other construction activities contain chemicals known to cause cancer, birth defects, or other reproductive harm. Some

examples of these chemicals are:

- Lead from lead-based paints, and
- Crystalline silica from bricks and concrete and other masonry products.

Your risk of exposure to these chemicals varies depending on how often you do this type of work. To reduce your risk work in a well ventilated area, use a dust control system, such as an industrial-style vacuum, and wear approved personal safety equipment, such as a dust/particle respirator designed to filter out microscopic particles.

Equipment Instruction Manual

EDCO Model TMC-7, TG-7 & EDG-7

Table of Contents

| <u>Section</u> | <u>Page Number</u> |
|--|--------------------|
| Specifications..... | 3 |
| Safety Guidelines..... | 4 |
| Operating Instructions..... | 5-6 |
| Maintenance Instructions and Schedule..... | 7 |
| Limited Equipment Warranty..... | Back Cover |

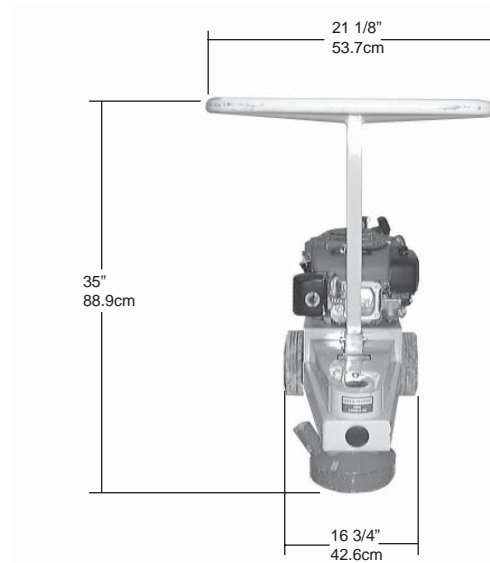
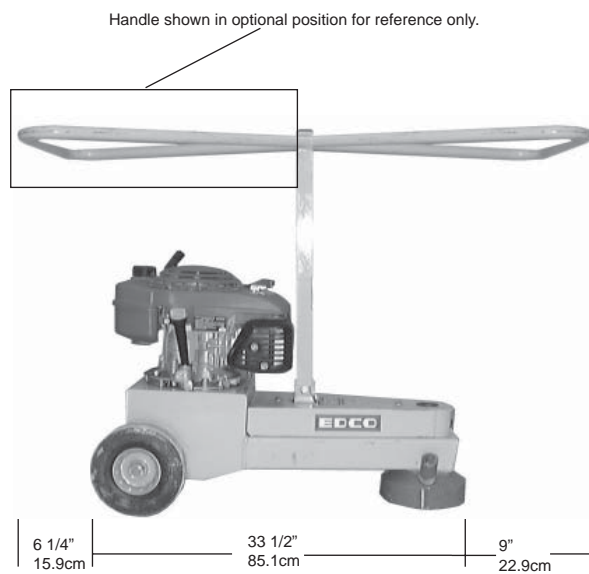

TG-7 Shown

Figure 1

HOW TO ORDER REPAIR PARTS

To ensure product safety and reliability, always use genuine EDCO replacement parts when making repairs to the equipment.

When ordering parts, please specify the MODEL and SERIAL NUMBER of the machine as given on the NAMEPLATE. In addition, give part number, description and quantity as listed on the parts list.

Please note: Due to improvements and changes in the equipment the illustrations shown may be different from the actual machine.

Toll Free: Voice 1-800-638-3326 • Fax 1-800-447-3326

Specifications and dimensions are approximate and subject to change.

| Model | TMC-7 | EDG-7 | TG-7 |
|--------|-------------------|-----------------|------------------|
| Height | 38.5" 98cm | 37" 95cm | 35" 89cm |
| Width | 24" 61cm | 21" 53cm | 21" 53cm |
| Length | 40" 102cm | 40" 102cm | 40" 102cm |
| Weight | 120 lbs 54.4kg | 132 lbs 60kg | 117 lbs 53 kg |



100 Thomas Johnson Drive, Frederick, MD 21702-4600 USA
 Phone (301) 663-1600 • 1-800-638-3326
 Fax (301) 663-1607 • 1-800-447-3326
 Website: www.edcoinc.com
 Email: sales@edcoinc.com

Printed in USA
 ©2010
Page 3

Read and understand all operating instructions
before operating this equipment.



Death or serious injury can result if this machine is used improperly.



Safety Guidelines



Eye and ear protection must be worn at all times while the grinder is in use. During normal operation, sound pressure levels may exceed 92dBA. Use only ANSI approved safety glasses to help prevent eye injury. Everyday eyeglasses have only impact resistant lenses; they are NOT safety glasses.



Operator must wear appropriate clothing and footwear. Do not wear loose clothing or jewelry that can get tangled in moving parts. Footwear should provide sure footing and protection.



Materials being removed can be toxic or hazardous. A breathing respirator is required to help protect the operator from inhaling the airborne material when operating this machine.

- Inspect the work surface for cracks, uneven joints and foreign objects such as nails, screws and pipes. Damage to the disc and/or equipment may result which can also cause serious injury to the operator. Hazardous areas should be properly identified and clearly marked.
- The TMC-7, EDG-7 and TG-7 are designed to be controlled by a single operator .
- Inspect the discs carefully before installing. Do not use any questionable disc since serious personal injury and/or damage to property can result.
- Never operate this grinder while under the influence of drugs, alcohol or when taking medications that impair the senses or reactions, or when excessively tired or under stress.
- Be sure decals on the machine can be clearly read and understood. Replace worn or missing decals immediately,

Safety warnings and guidelines do not by themselves eliminate danger.
They are not given as substitutes for proper accident prevention procedures and good judgement.

Operating Instructions

The EDCO edge grinders are designed to be used in conjunction with other EDCO surface preparation products. It's small, lightweight construction allows the operator to grind close to obstacles.

These units are equipped with a single 7" diameter Diamond Segmented Disc that is an aggressive surface material grinder for removing excess concrete, epoxy mortar, urethane coatings and overlays, and non-skid abrasive coatings on steel, concrete, or polymer slab floors. A scarifier disc is optional. This machine is capable of either wet or dry grinding.

Before Operation:

- Before starting the engine, perform a visual inspection of the entire machine. Be sure all fasteners are tight and secure, check for signs of metal cracking or fatigue, inspect for damage. Be sure guards are in place, secure and undamaged.
- Inspect diamond grinding disc. Check for loose or damaged diamond segments and replace if necessary. Check that the diamond disc has been correctly mounted and be sure it is tight. Different diamond/matrix discs wear at different rates. Be sure to use the correct diamond/matrix combination for your specific application.

To Start Grinding:

- Operating the machine from the rear, push down, or if operating from the front, lift the handle very slightly to shift some of the weight off of the disc, but do not let the disc lift from the slab surface. The slight weight shift will aid the engine in reaching the operating speed without an excessive start-up power draw. Once the engine reaches operating speed, allow the edger-grinder to settle back down on the slab with the full weight on the disc.
- If the disc is out of balance, stop immediately and have the problem fixed or damage to the equipment will result.

For Wet Grinding:

- Water is not necessary as a coolant but rather as a means of controlling dust. Lightly dampen the floor or use a fine mist.

CAUTION

Do not use an excessive amount of water. Excess water on the surface will create a dangerous, slippery surface and more work during cleanup.

- Sprinkle a small amount of sand on the slab to create a slurry during grinding. The slurry tends to keep the diamonds free from build up and the cutting edge exposed. If a squeaking sound is heard or the machine tends to pull to one side, the diamond segments may have filled and are no longer grinding effectively. Discontinue use of machine. Make sure the throttle is completely closed (full stop position) to insure the engine will not accidentally fire (kick back) when removing the disc which could cause bodily injury and/or damage to the machine. Then follow the directions for replacing the diamond disc or optional scarifier disc.



For Dry Grinding:



Check materials being removed to determine if they are listed on an EPA hazardous substance list. A breathing respirator is required to help protect the operator.

- The EDCO VAC-100, VAC-160 and VAC-150 have available optional HEPA filter kits designed to be used when removing hazardous materials. Standard, shop-vac style vacuums are not capable of extended operation. In addition, these standard vacs use paper bag filters that can clog and overload the vacuum motor.
- Dry grinding creates a large volume of airborne dust. The edgers are equipped with a 1-1/2" vacuum port for attaching a high volume industrial vacuum capable of removing particles to three microns. If the materials involved are hazardous, or unknown and assumed hazardous, the operator must assume responsibility for the proper handling and disposal of the hazardous material.

Note: Hazardous debris, including vacuum filters, must be disposed of properly according to OSHA and government standards.

Replacing the Diamond Grinding Disc:

- Make sure the throttle is **fully closed** (full stop position) to insure there will be no accidental engine starting while cleaning or replacing the disc.
- To gain access to the disc, push down on the handle in the rear optional position (*Figure 1*) and pivot the unit back on the wheels until it comes to rest on the handle. (The belt tensioning bolt is also visible from this position.)
- Unbolt the diamond disc and remove the disc.
- Replace with a new disc by simply reversing the procedure.

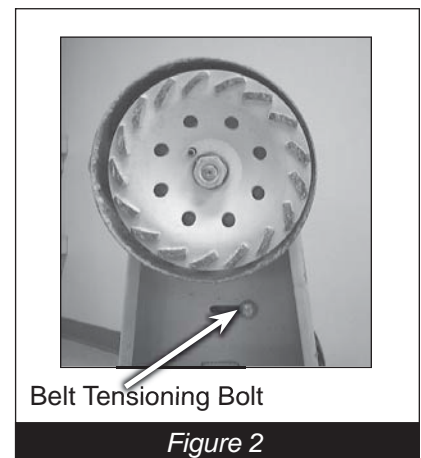

Figure 2

Inspect drive belt:

- Check belt tension. On new equipment, and after installing a new belt, the belt should be retensioned after the first four hours of use. A damaged, stretched, or worn belt should be replaced with a new one. (*Figure 3 - Shown with belt cover removed.*)
- Adjust belt tension (*Figure 3*). Loosen belt tensioning bolt (*Figure 2*) and slide pulley to provide more tension against drive belt.

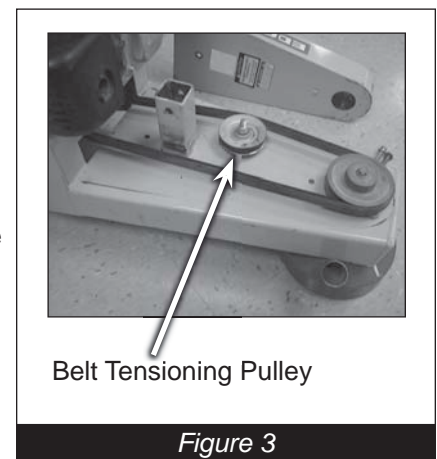

Figure 3

Maintenance



Make sure the throttle is completely closed (full stop position) to insure the engine will not accidentally fire (kick back) while performing any maintenance.

- All maintenance should be performed regularly and by qualified personnel only.
- Never work under equipment without first properly securing the equipment to prevent it from moving or falling. Always work on a flat and level surface.
- Grease disc bearings every 4 hours of use. To access the bearings on the EDG-7 and TG-7, simply remove the front cap-plug cover (*Figure 4*) with a flat screwdriver. Both of the bearings are self-aligning, sealed flange mounted, equipped with grease fittings. To access the fitting on the TMC-7 refer to (*Figure 4A*). These bearings are tapered roller bearings lubricated with High Temp Lubriplate No. 930-AA, or equivalent bearing grease. Do not over lubricate. Be sure to clean up any excess grease after lubricating the bearings. These bearings can occasionally require adjustment. If it is evident that these bearing need adjustment they can be accessed by removing the belt cover.
- Lubricate the wheel bearings from time to time with an occasional drop or two of oil to prevent binding.
- To tension the belt, the Grinders are outfitted with a tensioning pulley (*Figure 3*). Proper belt tension must be maintained to transmit the motor power to the grinding disc. Damage to the motor will occur and disk life shortened if belts are not kept at the proper tension.
- Keep the Grinders clean. Be sure the safety decals are readable and properly maintained on the machine.

| Quick Reference For Maintaining Grinders | Before Operation | Daily | After Each Use | As Required |
|--|------------------|-------|----------------|-------------|
| Engine Air Filter | | | | X |
| Visual Inspection of Entire Machine | X | | | |
| Inspect Diamond Disc | X | | | |
| Grease Bearings | | X | | |
| Clean dust and dirt off machine | | | X | |
| Inspect Belt and Belt Tensioning | | | | X |

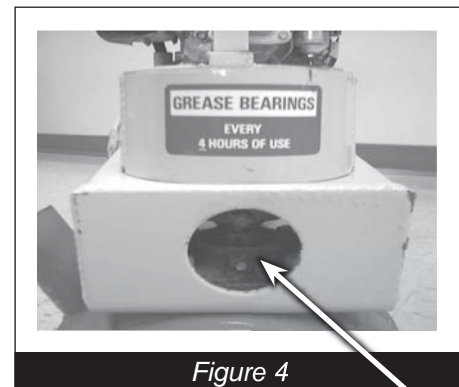

Figure 4

Grease fittings

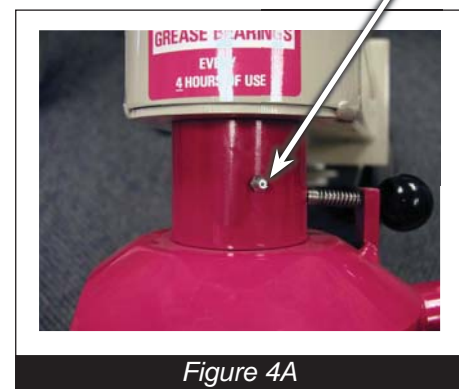

Figure 4A

LIMITED EQUIPMENT WARRANTY OF SALE – TERMS & CONDITIONS

Equipment Development Company, Inc. herein referred to as EDCO (Seller) warrants that each new unit manufactured by EDCO to be free from defects in material and workmanship in normal use and service for a period of (1) one year (except for the cutter drum assembly on all model concrete/asphalt planes, in which case the warranty period shall be 90 days) and (VAC) motors, in which case the warranty period shall be (2) two years) from date of shipment to the original retail or equipment rental center owner.

Accessories or equipment furnished and installed on the product by EDCO but manufactured by others, including, but not limited to engines, motors, electrical components, transmissions etc., shall carry the accessory manufacturers own warranty.

EDCO will, at its option, repair or replace, at the EDCO factory or at a point designated by EDCO, any part which shall appear to the satisfaction of EDCO inspection to have been defective in material or workmanship.

EDCO reserves the right to modify, alter and improve any part or parts without incurring any obligation to replace any part or parts previously sold without such modified, altered or improved part or parts.

This warranty is in lieu of and excludes all other warranties, expressed, implied, statutory, or otherwise created under applicable law including, but not limited to the warranty of merchantability and the warranty of fitness for a particular purpose in no event shall seller or the manufacturer of the product be liable for special, incidental, or consequential damages, including loss of profits, whether or not caused by or resulting from the negligence of seller and/or the manufacturer of the product unless specifically provided herein. In addition, this warranty shall not apply to any products or portions thereof which have been subjected to abuse, misuse, improper installation, maintenance, or operation, electrical failure or abnormal conditions and to products which have been tampered with, altered, modified, repaired, reworked by anyone not approved by seller or used in any manner inconsistent with the provisions of the above or any instructions or specifications provided with or for the product.

FORCE MAJEURE

Seller's obligation hereunder are subject to, and Seller shall not be held responsible for, any delay or failure to make delivery of all or any part of the Product due to labor difficulties, fires, casualties, accidents, acts of the elements, acts of God, transportation difficulties, delays by a common carrier, inability to obtain Product, materials or components or qualified labor sufficient to timely perform part of or all of the obligations contained in these terms and conditions, governmental regulations or actions, strikes, damage to or destruction in whole or part of manufacturing plant, riots, terrorist attacks or incidents, civil commotions, warlike conditions, flood, tidal waves, typhoon, hurricane, earthquake, lightning, explosion or any other causes, contingencies or circumstances within or without the United States not subject to the Seller's control which prevent or hinder the manufacture or delivery of the Products or make the fulfillment of these terms and conditions impracticable. In the event of the occurrence of any of the foregoing, at the option of Seller, Seller shall be excused from the performance under these Terms and Conditions, or the performance of the Seller shall be correspondingly extended.

This document sets forth the terms and conditions pursuant to which the purchaser ("Purchaser") will purchase and Equipment Development Co. Inc. ("Seller") will sell the products, accessories, attachments (collectively the Products) ordered by the Purchaser. These terms and conditions shall govern and apply to the sale of Seller's Products to Purchaser, regardless of any terms and conditions appearing on any purchase order or other forms submitted by Purchaser to Seller, or the inconsistency of any terms therein and herein.

1. PRICE

All prices set forth on any purchase order or other document are F.O.B. Sellers facility or distribution point, as may be determined by Seller (F.O.B. Point). All prices are exclusive of any and all taxes, including, but not limited to, excise, sales, use, property or transportation taxes related to the sale or use of the Products, now or hereafter imposed, together with all penalties and expenses. Purchaser shall be responsible for collecting and/or paying any and all such taxes, whether or not they are stated in any invoice for the Products. Unless otherwise specified herein, all prices are exclusive of inland transportation, freight, insurance and other costs and expenses relating to the shipment of the Products from the F.O.B. point to Purchaser's facility. Any prepayment by Seller of freight insurance and other costs shall be for the account of Purchaser and shall be repaid to Seller.

2. PAYMENT TERMS

Payment terms are as follows. 2% 10 days (to approved and qualified accounts). Net 30 days. This is a cash discount for invoices paid within 10 days after the invoice date, regardless of date of receipt of shipment. This is not a trade discount and will not be granted to accounts that do not adhere to stated terms.

*All past due accounts are subject to a late payment fee of 1.5% per month or a maximum allowed by law if different, along with the expenses incidental to collection including reasonable attorney's fees and costs.

*Seller reserves the right to hold shipments against past due accounts.

*Seller reserves the right to alter payment terms.

3. FREIGHT TERMS

All shipments will be made F.O.B. shipping point as designated in these Terms and Conditions, and title shall pass at the F.O.B. point. Delivery to the initial common carrier shall constitute delivery to the Purchaser. Any claims for loss or damage during shipment are to be filed with carrier by the Purchaser. Seller will not assume responsibility for the performance of the carrier.

Back orders will be shipped in the most practical fashion with charges consistent with our freight policy established with the original order. UPS, FED EX, MAIL or shipments by other couriers are subject to the same terms and conditions as outlined in paragraph #3 "Freight Terms".

4. DELIVERY, DAMAGES, SHORTAGES

Seller shall use reasonable efforts to attempt to cause the Products to be delivered as provided for in these Terms & Conditions. Delivery to the initial common carrier shall constitute the delivery to the Purchaser. Seller's responsibility, in so far as transportation risks are concerned ceases upon the delivery of the Products in good condition to such carrier at the F.O.B. point and all the Products shall be shipped at the Purchaser's risk. Seller shall not be responsible or liable for any loss of income and/or profits, or incidental, special, consequential damages resulting from Seller's delayed performance in shipment and delivery.

5. RETURN OF DEFECTIVE PRODUCTS

Defective or failed material shall be held at the Purchaser's premises until authorization has been granted by Seller to return or dispose of Products. Products that are to be returned for final inspection must be returned Freight Prepaid in the most economical way. Credit will be issued for material found to be defective upon Seller's inspection based on prices at time of purchase.

6. PRODUCTS ORDERED IN ERROR

Products may be returned, provided that claim is made and Seller is notified within 7 days of receipt of Products, and the Products are in original buyer's possession not more than 30 days prior to return, subject to Seller's approval. If Products are accepted for return, they must be Freight Prepaid and buyer will be charged a minimum of 15% restocking charge, plus a charge back for outbound freight charges if the original order was shipped prepaid. Returns are not accepted for any Products that are specifically manufactured to meet the buyer's requirement of either specifications or quantity.

AGREEMENTS

These Terms and Conditions constitute the entire agreement between Seller and Purchaser as it relates to terms and conditions of sale, and supersedes any and all prior oral or written agreements, correspondence, quotations or understandings heretofore in force between the parties relating to the subject matter hereof. There are no agreements between Seller and Purchaser with respect to the Product herein except those specifically set forth in and made part of these terms and conditions. Any additional terms, conditions and/or prices are rejected by Seller.

These terms and conditions may be modified, cancelled or rescinded only by a written agreement of both parties executed by their duly authorized agents.

USE ONLY GENUINE EDCO PARTS & ACCESSORIES

For your own safety, the safety of others and the life of your machine.

Equipment Development Company, Inc.